

## 12327

Cylinder mounting squeeze block  
(for SM-6)

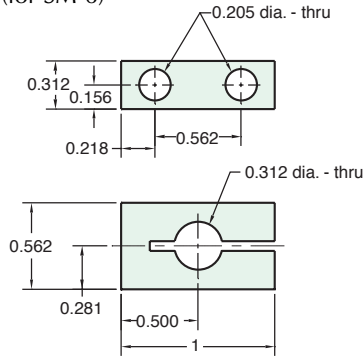

## CMB

Column and mounting base  
(black oxide finished steel)

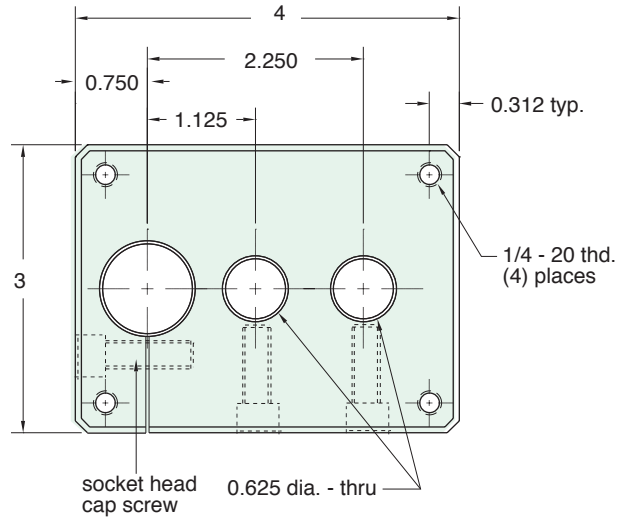

## 12326-□

Cylinder mounting squeeze blocks  
(for 3/8" & 9/16" standard bore)

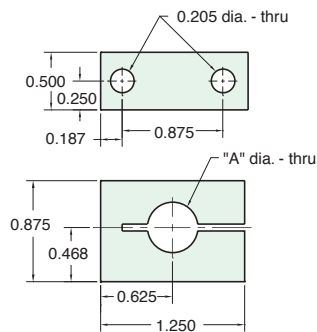

| Part #         | "A"   |                                  |
|----------------|-------|----------------------------------|
| <u>12326-1</u> | 5/8"  | (for 9/16" stand. bore cylinder) |
| <u>12326-2</u> | 7/16" | (for 3/8" stand. bore cylinder)  |

## 12366-□

Fixture and bracket mounting shafts  
(black oxide finished steel)

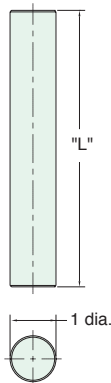

| Part #          | "L" |
|-----------------|-----|
| <u>12366-4</u>  | 4"  |
| <u>12366-6</u>  | 6"  |
| <u>12366-8</u>  | 8"  |
| <u>12366-10</u> | 10" |
| <u>12366-12</u> | 12" |
| <u>12366-14</u> | 14" |
| <u>12366-16</u> | 16" |
| <u>12366-18</u> | 18" |
| <u>12366-20</u> | 20" |

